

Latest Updated 2002-02-14



Wide voltage range contactors AF 145...AF 750



ABB

Selection table / Technical data



3-pole contactors		Type	AF 145	AF 185	AF 210	AF 260	AF 300	AF 400	AF 460	AF 580	AF 750	
Rated operational power AC-3												
	$\theta \leq 55^\circ\text{C}$	220-230-240 V	kW	45	55	59	80	90	110	132	160	220
		380-400 V	kW	75	90	110	140	160	200	250	315	400
		415 V	kW	75	90	110	140	160	220	250	355	425
		440 V	kW	75	90	110	140	160	220	250	355	450
		500 V	kW	90	110	132	180	200	250	315	400	520
		690 V	kW	110	132	160	200	250	315	355	500	600
Rated operational current I_e/AC-3												
	$\theta \leq 55^\circ\text{C}$	220-230-240 V	A	145	185	210	260	305	400	460	580	750
		380-400 V	A	145	185	210	260	305	400	460	580	750
		415 V	A	145	185	210	260	300	400	460	580	750
		440 V	A	145	185	210	240	280	400	460	580	750
		500 V	A	145	170	210	240	280	400	460	580	750
		690 V	A	120	170	210	220	280	350	400	500	650
Rated operational current I_e/AC-1												
U_e max. 690 V	$\theta \leq 40^\circ\text{C}$	A	250	275	350	400	500	600	700	800	1050	
	$\theta \leq 55^\circ\text{C}$	A	230	250	300	350	400	500	600	700	800	
	$\theta \leq 70^\circ\text{C}$	A	180	180	240	290	325	400	480	580	720	
	with conductor cross-sectional area	mm ²	120	150	185	240	300	2x185	2x240	2x240	2x80x5	
gG (gl) max. fuses			A	315	355	400	500	500	630	800	1000	1000
UL / CSA data												
Continuous ampere rating			A	230	250	300	350	400	550	650	750	780
Motor rating 3-phase												
	200-208 V	HP	40	50	60	75	100	125	150	250	250	
	220-240 V	HP	50	60	75	100	100	150	200	250	300	
	440-480 V	HP	100	125	150	200	250	350	400	500	600	
	550-600 V	HP	125	150	200	250	300	400	500	600	700	
Max. switching frequency												
	Mechanical	cycles/h	300			300			300			
	for AC-1	cycles/h	300			300			300			
	for AC-3	cycles/h	300			300			300			
	for AC-4	cycles/h	150			60			60			
Coil consumption												
	- pull-in a.c.	VA/W	250/250			400/400			800/800		600/600	
	- pull-in d.c.	W	350			450			900		700	
	- holding a.c.	VA/W	2.5/2.5			2.5/2.5			4/4		3.3/3.3	
	- holding d.c.	VA/W	3			1			4.5		4	
Thermal O/L relays												
	Type		TA 200 DU			TA 450 DU						
	Setting range	A	66-200			130-310						
Electronic O/L relays												
	Type		E 200 DU		E 320 DU		E 500 DU		E 800 DU			
	Setting range	A	60-200		100-320		150-500		250-800			

Ordering details / General Information

Rated operational current			Auxiliary contacts fitted	Type	Order code		Weight kg
AC-3 380 V 400 V A	AC-1 415 V $\theta \leq 40^\circ\text{C}$ A A				coil voltage in clear text : <input type="text"/>	coil voltage code see table below : <input type="checkbox"/> <input type="checkbox"/>	
145	145	250	1 1 2 2	AF 145-30-11 <input type="text"/> AF 145-30-22 <input type="text"/>	1SFL 47 7001 R <input type="checkbox"/> <input type="checkbox"/> 11 1SFL 47 7001 R <input type="checkbox"/> <input type="checkbox"/> 22	3.600 3.600	
185	185	275	1 1 2 2	AF 185-30-11 <input type="text"/> AF 185-30-22 <input type="text"/>	1SFL 49 7001 R <input type="checkbox"/> <input type="checkbox"/> 11 1SFL 49 7001 R <input type="checkbox"/> <input type="checkbox"/> 22	3.600 3.600	
210	210	350	1 1 2 2	AF 210-30-11 <input type="text"/> AF 210-30-22 <input type="text"/>	1SFL 51 7001 R <input type="checkbox"/> <input type="checkbox"/> 11 1SFL 51 7001 R <input type="checkbox"/> <input type="checkbox"/> 22	6.200 6.200	
260	260	400	1 1 2 2	AF 260-30-11 <input type="text"/> AF 260-30-22 <input type="text"/>	1SFL 53 7001 R <input type="checkbox"/> <input type="checkbox"/> 11 1SFL 53 7001 R <input type="checkbox"/> <input type="checkbox"/> 22	6.200 6.200	
305	300	500	1 1 2 2	AF 300-30-11 <input type="text"/> AF 300-30-22 <input type="text"/>	1SFL 55 7001 R <input type="checkbox"/> <input type="checkbox"/> 11 1SFL 55 7001 R <input type="checkbox"/> <input type="checkbox"/> 22	6.200 6.200	
400	400	600	1 1 2 2	AF 400-30-11 <input type="text"/> AF 400-30-22 <input type="text"/>	1SFL 57 7001 R <input type="checkbox"/> <input type="checkbox"/> 11 1SFL 57 7001 R <input type="checkbox"/> <input type="checkbox"/> 22	12.000 12.000	
460	460	700	1 1 2 2	AF 460-30-11 <input type="text"/> AF 460-30-22 <input type="text"/>	1SFL 59 7001 R <input type="checkbox"/> <input type="checkbox"/> 11 1SFL 59 7001 R <input type="checkbox"/> <input type="checkbox"/> 22	12.000 12.000	
580	580	800	1 1 2 2	AF 580-30-11 <input type="text"/> AF 580-30-22 <input type="text"/>	1SFL 61 7001 R <input type="checkbox"/> <input type="checkbox"/> 11 1SFL 61 7001 R <input type="checkbox"/> <input type="checkbox"/> 22	15.000 15.000	
750	750	1050	1 1 2 2	AF 750-30-11 <input type="text"/> AF 750-30-22 <input type="text"/>	1SFL 63 7001 R <input type="checkbox"/> <input type="checkbox"/> 11 1SFL 63 7001 R <input type="checkbox"/> <input type="checkbox"/> 22	15.000 15.000	

Coil voltages and codes AF 145 ... AF 750

Voltage (V) 50...60 Hz : <input type="text"/>	Voltage (V) (DC) <input type="text"/>	Voltage code : <input type="checkbox"/> <input type="checkbox"/>
-	24...60	<input type="checkbox"/> <input type="checkbox"/>
-	20...60	<input type="checkbox"/> <input type="checkbox"/>
48...130	48...130	<input type="checkbox"/> <input type="checkbox"/> ¹⁾
100...250	100...250	<input type="checkbox"/> <input type="checkbox"/>

code 68
24 - 60 V DC; only for AF 400...AF 750

code 72
20 - 60 V DC; only for AF 145...AF 300

1) Available mid 2001

General

The AF contactors are fitted with an electronic coil interface. For a given coil, this interface allows the contactor to accept a wide control / supply voltage range in d.c. as well as in a.c. (50/60Hz).

The current flow through the coil is a regulated d.c. current and is therefore independent from the control voltage level and frequency.

Operating advantages:

- ◆ Reduced holding coil consumption
- ◆ The device withstands large control voltage variations without nuisance reopening
- ◆ Distinct opening and closing with no chattering and minimal bounce, eliminating the major cause of contact welding and coil burning.
- ◆ No voltage transients at opening
- ◆ Wide voltage range (a.c./d.c.)

The framesizes AF 400...AF 750 have a PLC input as standard, which means that they can be directly controlled with low voltage signals.

Accessories

AF contactor accessories are the same as those of standard A contactors of equal rating.

Dimensions / Control circuit diagram

Dimensions

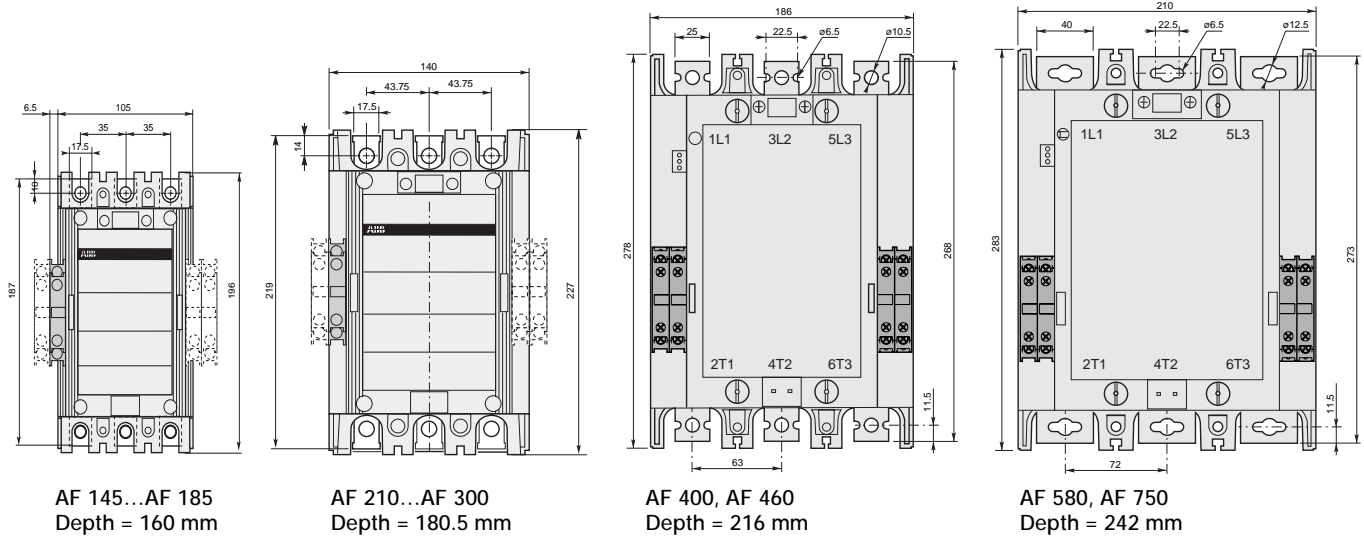

Control circuit diagram

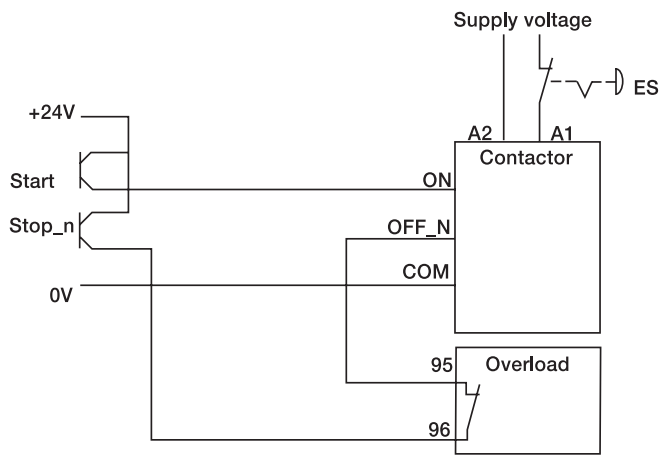

Control with low voltage signals (PLC)
AF 400...AF 750

Operating diagram

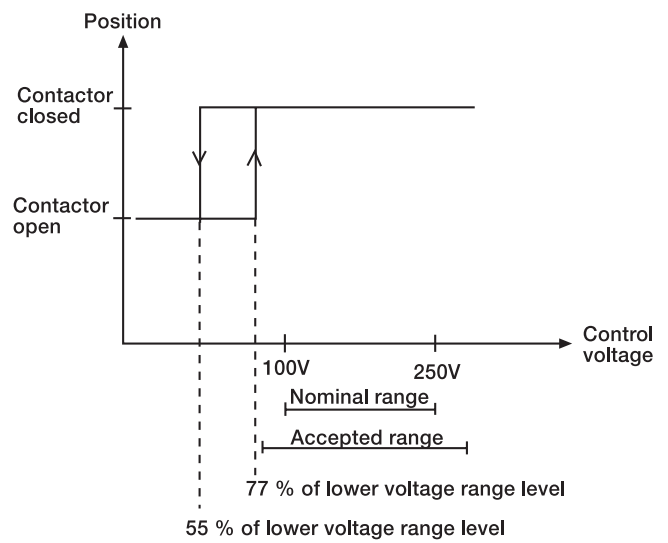

Control with control voltage on A1 and A2
(example with code -70)

