

# ACS 6000

Medium Voltage AC Drives for Speed and Torque Control of 3 – 27 MW Motors



IndustrialIT  
enabled™

**ABB**



# ACS 6000 - The World's most Successful MV Multidrive

ABB's ACS 6000 medium voltage drive provides the optimum solution for applications where high power and maximum reliability is required. Since its introduction, the ACS 6000 has gained an excellent reputation for high quality and reliability. As a result ABB has worldwide the largest installed base of medium voltage multidrives incorporating the latest technology.

ABB's ACS 6000 is a modular drive designed for the most demanding single-motor or multi-motor applications. The optimum configuration for each application is reached by combining the modules with minimum engineering effort resulting in lower investment costs and a smaller footprint. It is available with four sizes of inverter modules (3, 5, 7 and 9 MVA).

Several motors can be linked to the ACS 6000 via the common DC bus, enabling multi-machine operation with only one multidrive converter. A multidrive, common DC bus converter principle offers a solution with optimum efficiency.

The ACS 6000 medium voltage drive can be used in a wide range of industries.

## ACS 6000 Success

- Average annual increase of more than 100% since product launch
- Largest installed base of medium voltage multidrives worldwide
- Operation experience of more than 100 years

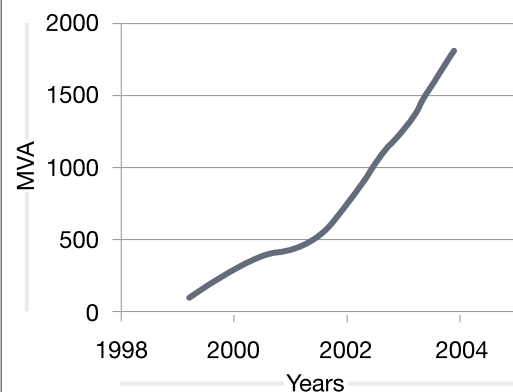

## Fields of Application

Industries	Applications
Cement, Mining and Minerals	Mine hoists, conveyors, crushers and mills
Chemical, Oil and Gas	Pumps, compressors, extruders, mixers and blowers
Marine	Main propulsion, thrusters, pumps and compressors
Metals	Rolling mills, coilers, pumps and fans
Pulp and Paper	Fans, pumps, refiners and chippers
Power Generation	Fans and pumps
Water and Waste Water	Pump applications, fresh water and waste water
Other Applications	Test stands and wind tunnels

# Key Features

The ACS 6000 medium voltage drive for speed and torque control of 3 – 27 MW induction or synchronous motors is a member of the ABB AC drives product family. It offers a number of unique key features.

## Powerful Performance

Fast and accurate process control in combination with low energy consumption results in top performance. The motor control platform of the ACS 6000 is based on ABB's award-winning Direct Torque Control (DTC) technology. DTC provides the highest torque and speed performance ever achieved in medium voltage drives. As a result, control of the drive is immediate and smooth under all conditions.

## High Efficiency and Reliability

The ACS 6000 uses a revolutionary power semiconductor switching device known as IGCT (Integrated Gate Commutated Thyristor) researched and designed by ABB. The use of IGCTs results in a less complex, more efficient and reliable medium voltage drive, minimizing operating and maintenance costs.

## Key Product Features

- **DTC Control Platform** for exceptionally high torque and speed performance
- **IGCT Power Semiconductors** for highest reliability and efficiency
- **Line Supply Unit** for two-quadrant operation with a constant power factor of 0.96 over the whole speed range
- **Active Rectifier Unit** for four-quadrant operation and reduced harmonics, adjustable power factor
- **Common DC Bus** for single and multiple-motor operation and energy recuperation
- **Modular Design** for optimum configurations

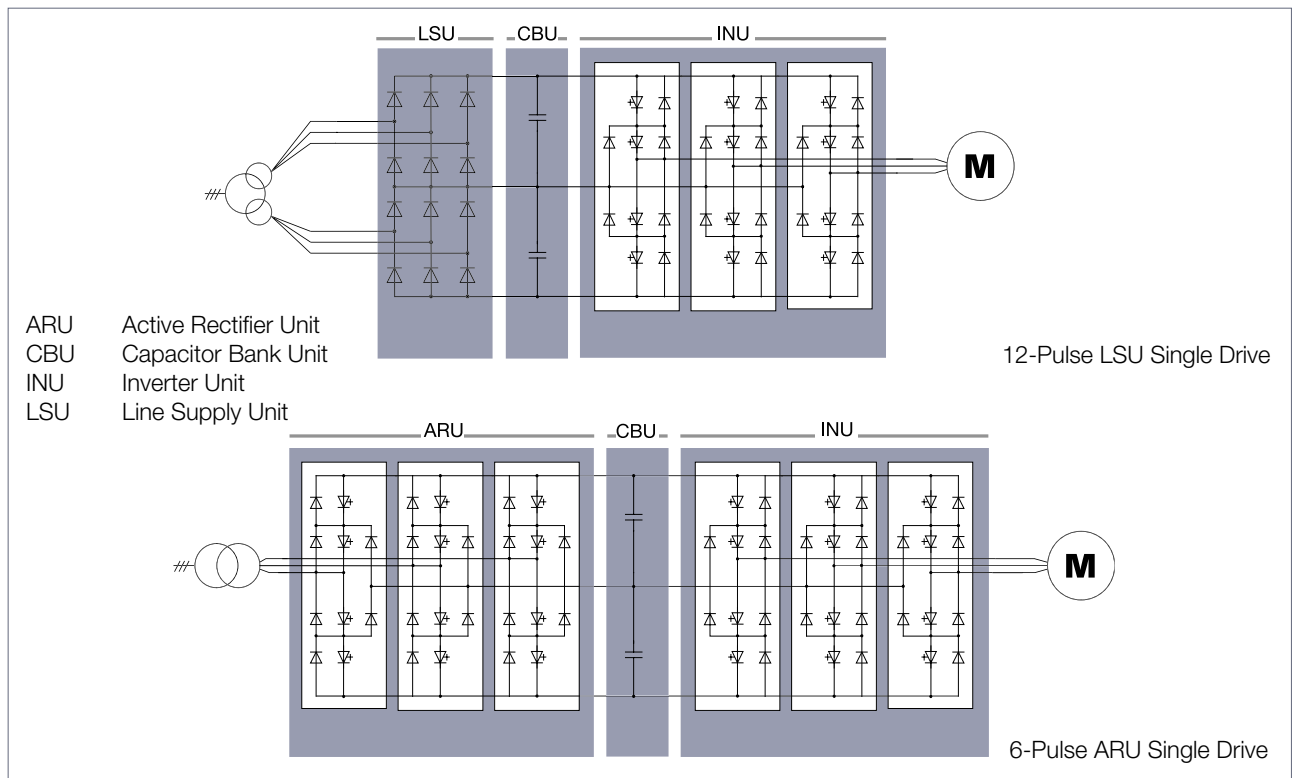

The ACS 6000 inverter topology

### High Availability

Maximum reliability and short repair time results in a drive with high availability.

### Optimized Energy Flow

The common DC bus allows several motors to be connected to the same DC bus, providing an optimized energy flow.

The braking energy generated in one motor can be transferred to other inverters via the common DC bus without power consumption from the supply network. Due to the near unity power factor throughout the whole speed range the energy efficiency is optimal.

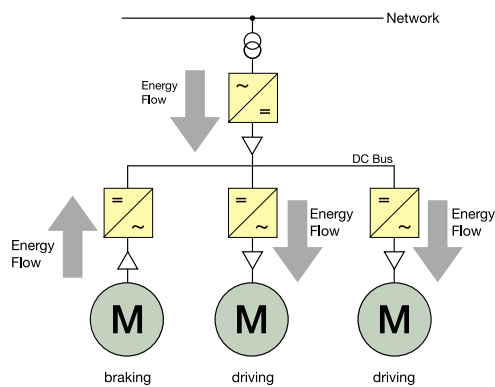

Optimized energy flow with common DC bus  
e.g. cold reversing steel mill

### ACS 6000 Advantages

- High power and maximum reliability
- Smooth torque over the entire speed range
- Applications operate at optimum efficiency
- Compact and high power density
- Low noise and vibration levels
- Minimized energy consumption with common DC bus
- Regeneration of rotating energy

### Flexible

#### Optimum Configuration

The modular design of the ACS 6000 allows the optimum configuration of any drive system. Each configuration, consisting of well-proven and certified modules, exactly fits the customer's requirements.

#### Smooth System Integration

The ACS 6000 integrates easily into the industrial environment because it can be optimally configured for single-motor and multi-motor applications without additional control equipment. The high power density and compact design and the drive's communication abilities minimize the overall installation and operational costs.

The drive can be connected to the network through one or several transformers depending on power and harmonics requirements. Even a transformerless solution is available for certain applications.

# The ACS 6000 Medium Voltage AC Drive

## Water-cooled

EMC compliant cabinet for problem-free operation in electromagnetic environment

DC bus grounding switch for safety



User-friendly control panel for local operation

- Keypad with multi-language display
- Main supply on/off pushbuttons
- Emergency stop pushbutton

Electromechanically interlocked doors of power sections for safety

Power Electronic Building Block (PEBB), one phase leg of a three-level Voltage Source Inverter (VSI) topology to be configured to act as an AC to DC or DC to AC converter

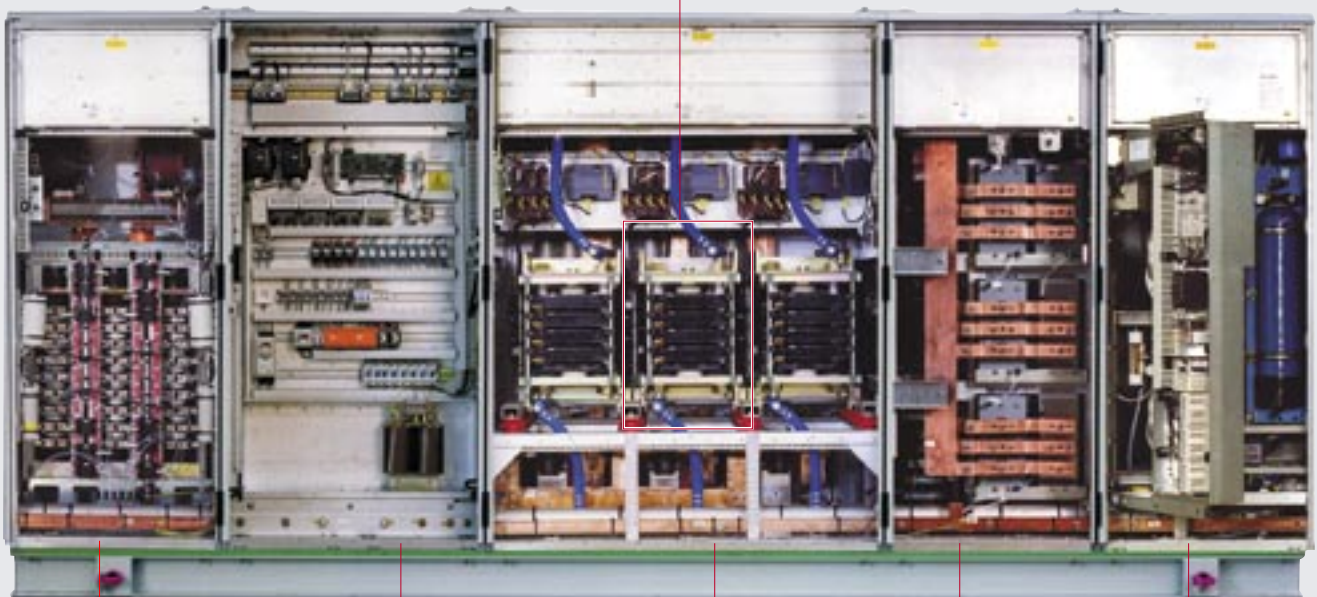
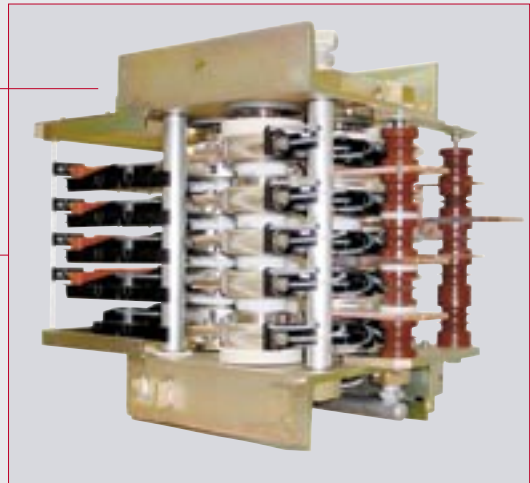

Line Supply Unit (LSU)  
6- or 12-pulse diode  
rectifier unit

Inverter Unit (INU)  
Self-commutated,  
6-pulse, 3-level voltage  
source inverter with  
IGCT technology

Water Cooling Unit (WCU)  
Supplies the cooling  
system with deionized  
water for the main power  
components in LSU, INU  
and CBU

Terminal Unit (TEU)  
and Control Unit (COU)  
Contains the power  
terminals and the  
control swing frame

Capacitor Bank Unit (CBU)  
DC capacitors for  
smoothing the  
intermediate DC voltage

# Technology Highlights

Reliability has been the main guiding principle of the research and development activities for ABB's medium voltage AC drives.

## Part Count

The fewer the parts the higher the reliability. ABB uses high power semiconductor switching devices and a topology that brings down the part count to a minimum. This results in a reliable, compact and service-friendly drive.

## Fuseless Design

The ACS 6000 medium voltage drive is designed to operate safely without fuses, resulting in less spare parts and better overall reliability. This allows fast startup after safety interruptions.

## Encoderless

Encoders are known to cause failures due to their exposed position on the motor. ABB's ACS 6000 medium voltage drive can operate without encoder, thereby reducing maintenance costs and ensuring high levels of availability.

## IGCT Switching Devices

ABB has developed a high power semiconductor called IGCT (Integrated Gate Commutated Thyristor) to allow the use of modern control algorithms, which can eliminate harmonics, improve dynamic response time and maintain, or even control, the power factor.

## Low Losses

The inherently low total losses of the IGCT require low cooling capacity and small cooling equipment.

## Control

The ACS drive control platform is based on ABB's award-winning Direct Torque Control (DTC), resulting in the highest torque and speed performance as well as lowest losses ever achieved in medium voltage drives. Control of the drive is immediate and smooth under all conditions and the audible noise in the motor is considerably reduced.



## What is Direct Torque Control?

DTC is a revolutionary motor control method for AC drives that allows accurate control of both motor speed and torque without pulse encoder feedback from the motor shaft.

In DTC, stator flux and torque are used as primary control variables. The motor state calculations are updated 40,000 times a second (i.e. every 25  $\mu$ s) in the advanced motor software model by the high-speed digital signal processor. Due to the continuous updating of the motor state and the comparison of the actual values to the reference values, every single switching in the inverter is determined separately.

DTC ensures the absolute lowest losses by switching the power semiconductors only when necessary.

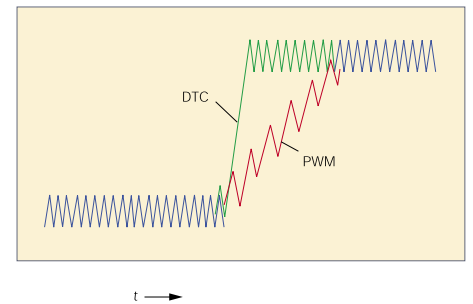

Typical torque (T) response of a DTC drive, compared with flux vector control with open loop pulse width modulation (PWM)

## Fast Response to Mains Fluctuations and Process Side Changes

The exceptionally fast torque step response of the ACS 6000 means that it can respond to process and mains changes extremely fast. This enables easy handling of power-loss situations and sudden load changes.



### Common DC Bus

The ACS 6000 modularity is based on the common DC bus converter principle, where several motors (synchronous and induction) can be connected to the same DC bus. With four sizes of inverter modules available (3, 5, 7 and 9 MVA), the optimum configuration for a specific application can be reached by combining the modules with minimum engineering effort. By linking the modules in parallel, the power can be increased to 27 MVA.

Multidrive topologies with a common DC bus offer a solution with optimum efficiency. Energy regenerated from one section in braking mode can be directly used by another section via the DC bus without power consumption from the supply network.

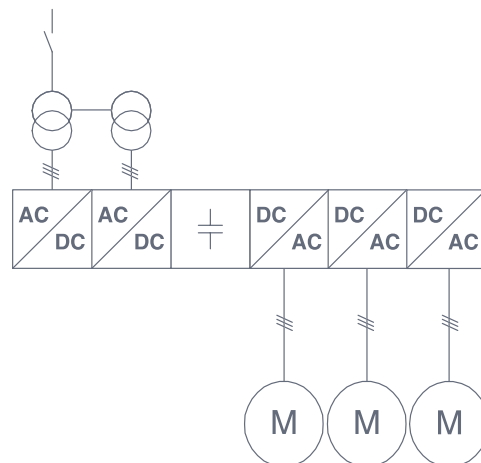

Diagram of common DC bus principle

### ACS 6000 Modules

#### Active Rectifier Unit (ARU) , Inverter Unit (INU)

The Active Rectifier Unit (ARU) rectifies the AC line voltage and charges the DC link capacitors whereas the Inverter Unit (INU) inverts the DC voltage to the AC motor voltage.

The layout and equipment of the INU and the ARU are identical. They are self-commutated, 6-pulse, 3-level voltage source inverters, incorporating IGCT technology for a reliable, fuseless operation with a smaller number of drive components.

The ARU allows four-quadrant operation for regenerative braking, which reduces the overall energy consumption.

It controls the power factor to unity in the whole operating range even at very low speeds.

Optionally the ARU can be dimensioned to compensate reactive power generated by other loads connected to the same network.

#### Line Supply Unit (LSU)

The Line Supply Unit (LSU), designed for two-quadrant operation, maintains the power factor at 0.96 in the whole operating range.

Typically, the LSU is used for applications which only require two-quadrant operation. If short-term braking capability is needed, a Resistor Braking Unit with internal or external resistors can be installed.

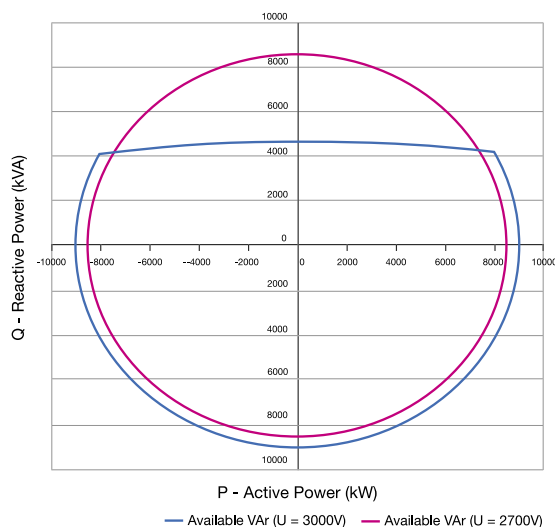

Diagram showing the available active and reactive power of the ARU

# Modular Use, One Design

The ACS 6000 is based on a modular product platform, expanding in line with customer's requirements.

The ACS 6000 is designed as a set of modules. The modules are arranged according to the required output power, motor configuration and process needs.

## Benefits of Modularity

- Converter rating optimally adapted to customer requirements.
- Each configuration consists of well-proven modules, minimizing the risk of design errors even when extensive systems are engineered.
- The compact, standardized design and the integrated water-cooling system reduce space requirements and have positive impacts on room air conditioning.
- Multidrive topologies with common DC bus are possible.
- Reduced installation and commissioning time.

Depending on the application, the following four basic types of configurations are used:

### • Single-Motor Drive Configurations

for synchronous, induction and permanent magnet motors. Single-motor configurations are commonly used in applications which require large, independent and decentralized drives.

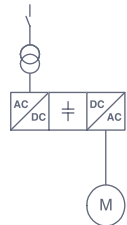

### • Redundant Drive Configurations

for motors with two winding systems. Single drives can be configured to allow redundancy offering greater availability of the drive system.

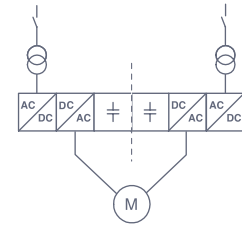

### • Multi-Motor Drive Configurations

for multiple synchronous or induction motors or a combination of both types. Up to five motors can be linked to a common DC bus, enabling multiple machine operation. Synchronous and/or induction motors, high or low power, any combination is possible in order to provide the optimum configuration.

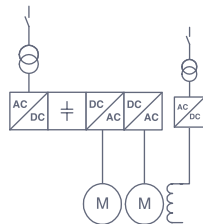

### • Twin Configurations

for motors with winding systems supplied on both ends by the converter. This allows higher converter output frequencies and double output voltage.

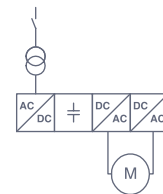

# ACS 6000 for Induction or Synchronous Motors

Depending on the power rating and the application characteristics, the ACS 6000 can be used with induction or synchronous motors.

## ACS 6000 for Induction Motors

Squirrel cage induction motors are the workhorses of the industry due to their versatility, reliability and simplicity. ABB's broad range of medium voltage AC induction motors includes ribbed cast iron fan cooled motors and modular type welded frame motors.

The ACS 6000 is typically used with induction motors for applications such as pumps, fans, compressors, conveyors, hoists, mills, crushers and propulsion systems.



## ACS 6000 for Synchronous Motors

Synchronous motors are typically considered for higher power ratings (e.g. above 8 MW to more than 100 MW). In addition to their high power capabilities, synchronous motors offer a wide field weakening range as well as the benefits of high efficiency and high performance.

The ACS 6000 synchronous drive is ideal for applications which require dynamic response and high torque, such as rolling mills and mine hoists and for high power applications, such as marine propulsion drives.

For special applications (e.g. low speed pumps) the ACS 6000 can be used with permanent magnet motors.



# System Integration

The ACS 6000 medium voltage drive with its modular concept allows optimum integration into the customer's industrial environment.

The ACS 6000 can either be installed to control just one motor, or to control several motors with comprehensive control features, minimizing overall installation and operational costs. The drive can be supplied by one or several transformers depending on power and harmonics requirements. Even a transformerless solution is available for certain applications.

## ACS 6000 System Integration

- Low network harmonics
- High power factor
- Optional reactive power (VAr) compensation
- Small footprint
- Fast commissioning
- EMC compliant

## Smooth Integration into Existing Systems

### Commissioning

The ACS 6000 is easy to commission. In its multidrive configuration, the ACS 6000 is much faster to commission than the equivalent number of single drives.

### Control System

ABB offers an open communication strategy enabling connection to a PLC (Programmable Logic Controller) or a DCS (Distributed Control System). Fieldbus connectivity with a wide variety of protocols is available.

The ACS 6000 product family platform offers the possibility to monitor the transformers as well as the motors with the drive's control system.

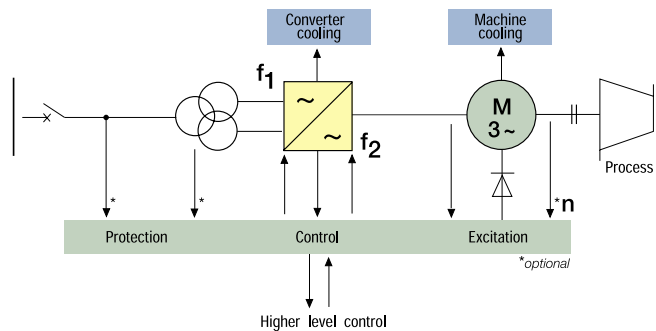

Scope of ACS 6000 system integration

### Applicable Standards

The ACS 6000 meets the IEEE 519-1992 and IEC 61000-2-4 specifications for voltage and current harmonic distortion for virtually all installations. This eliminates the need for expensive harmonic filters and protects other electrical equipment from harmonic disturbances.

The ACS 6000 meets EN (IEC), CE, UL\*, cUL\* and other standards to ensure smooth system integration worldwide.

\* on request

# Industrial<sup>IT</sup>

ABB's Industrial<sup>IT</sup> means increased standardization and seamless interaction of different ABB products. The ACS 6000 has been certified to bear the Industrial<sup>IT</sup> Enabled symbol, a special mark indicating that the drive can be easily integrated into the Industrial<sup>IT</sup> architecture in a 'plug & produce' manner.

## Benefits

- Easy integration of the drive into customer's industrial environment
- All drive information readily available in electronic form
- Drive communication with the environment through control panels, standardized fieldbus adapters and interfaces (OPC, OLE for Process Control)
- Easy to use start-up and maintenance tools

*Customer support systems for product training, help desk, service*

*Business systems for sourcing, ordering, spare parts*

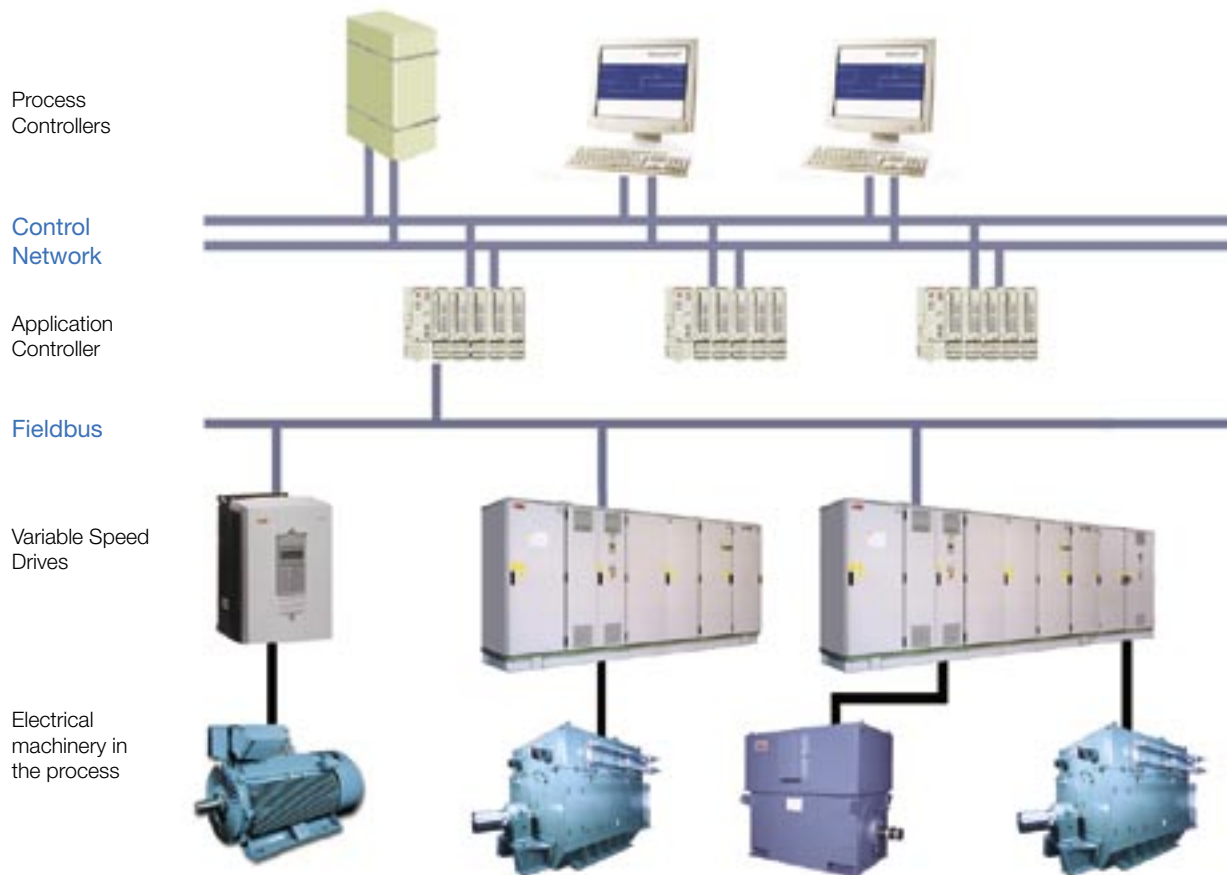

*Software for dimensioning, configuration, start-up, monitoring, documents*

*Software tools for energy calculations, efficiency analysis, new drive selection*

*The Principle of Industrial<sup>IT</sup>*

# Monitoring and control

The ACS 6000 is equipped with an intelligent monitoring and control system which allows secure access to the drive from any location in the world.

## Ethernet Adapter module (ETA)

ETA allows remote real-time access to the drive. It supports monitoring, configuration, diagnostics and control of ABB drives independent of the implemented control method, thus also enabling the connection of already existing installations.

Event-triggered e-mail messages will be sent to predefined addresses, allowing customers to quickly react to deviations. As ETA is compatible with any computer platform with a standard Web browser and Java support, the customer does not have to set up a PC with customized software.

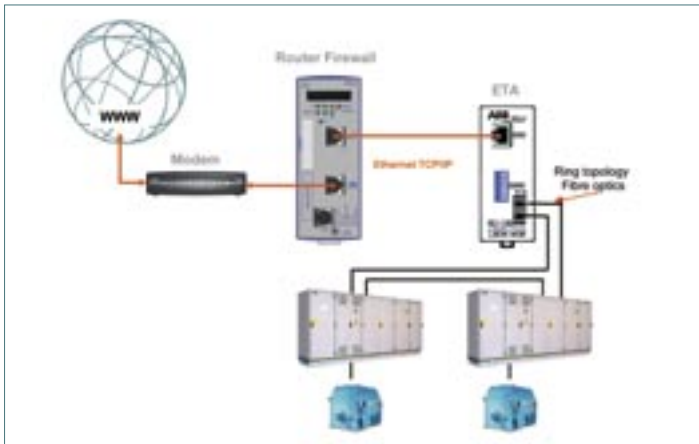

Principle of the Ethernet Adapter module (ETA)

## Features

- Connection of up to nine drives (new and existing installations)
- Compatible with all ABB drives
- Multilevel access protection
- ETA provides
  - drive status indication
  - parameter browsing and adjustment
  - data logger monitoring and set-up
  - fault logger monitoring
  - drive control functions (start, stop, reset, reference)

## DriveWindows, DriveOPC

In addition, the ACS 6000 incorporates the same suite of user-friendly tools as other drives of the ACS product family. These tools, DriveWindow and DriveOPC, enable communication between Windows®-based applications and ABB drives and simplify commissioning, maintenance, remote diagnostics and monitoring of the drive system.

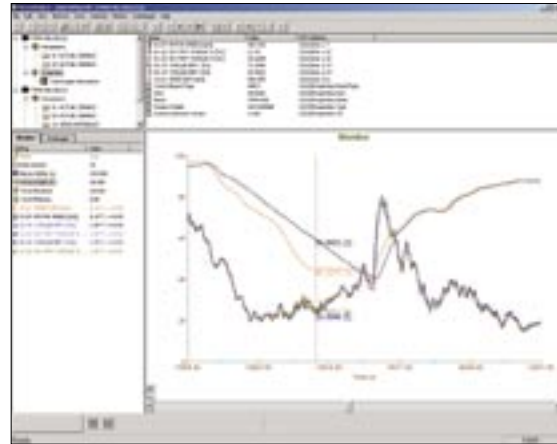

PrintScreen of DriveWindow

## Features

- Access to all drives connected to the same network
- Access to
  - drive control
  - signals and parameters
  - data and fault loggers
- Graphical presentation of signal values
- Monitoring and editing of drive signals and parameters off-line or on-line
- Back-up of drive parameters  
File can be easily reloaded
- Fault diagnosis with indication of drive status and fault history

# Service and Support

## Extensive Experience

As originators of AC drives technology in the late 1960's, ABB has over 30 years of application know-how in all industrial sectors, in virtually every country. ABB has listened to customers and strives to develop products which fulfill their needs.

## Dedicated Test Facility

Routine tests of the ACS 6000 include tests such as visual and mechanical checks, water pressure tests, insulation tests, auxiliary, control and protection devices checks and rated current and temperature rise tests of the Inverter Unit.

## ACS 6000 Single Drive

Tests of the ACS 6000 single drive additionally include load and functional tests on the test lab motor.

## ACS 6000 Multidrive

The multidrive modules are tested separately one by one as well as in a line-up, where the control functionality of the entire drive system is tested.

## Extended Testing

If required ABB also offers the possibility to perform extended testing in ABB's test facilities (see illustration).

## Support and Service

ABB's experts will assist in sizing, designing and commissioning the new drive.

After sales service is an integral part of providing the customer with a reliable and efficient drive system. ABB has the largest service organization worldwide, which backs every drive ABB delivers.

## Training

Extensive training for ABB's medium voltage drives can be provided at the ABB University in Turgi, Switzerland. A range of training is offered from basic tutorials to programs tailored to the customer's specific needs.

-> [www.abb.com/abbuniversity](http://www.abb.com/abbuniversity)

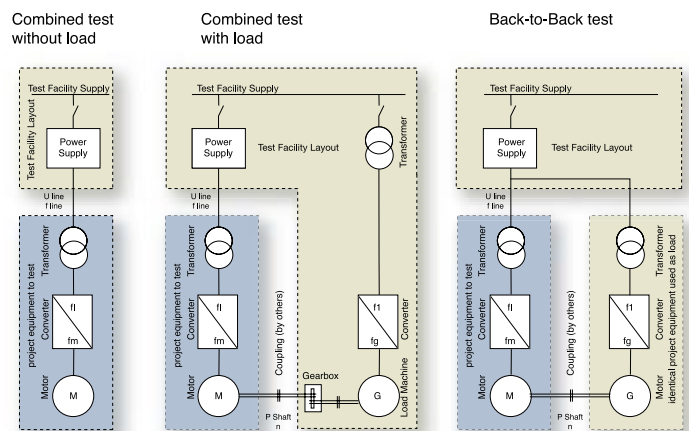

Illustration of extended test layouts

## Services for ABB's Medium Voltage Drives

- Installation and commissioning
- Training
- On-board diagnostics
- Remote diagnostics
- Customized service programs
- Local technical support
- Local service support
- Spare parts and logistics network
- Worldwide service network
- 24 x 365 support line



**ABB Switzerland Ltd**  
Medium Voltage Drives  
CH-5300 Turgi / Switzerland

Tel +41 (0)58 589 27 95  
Fax +41 (0)58 589 29 84  
Email [mvdrives@ch.abb.com](mailto:mvdrives@ch.abb.com)  
I-Net [www.abb.com/motors&drives](http://www.abb.com/motors&drives)